

Engineering Services Committee (ESC) meeting 21 June 2018

Summary from convenor water infrastructure subcommittee MDCA (Bruno Lemke)

The main ESC session was about approving new water restrictions protocol in the public water supply bylaw. These need to be put into place in case the Wiamea dam does not go ahead. In the higher levels of the water restriction protocol (E and F), "all use of water for purposes other than essential human and animal health and safety would need to stop. In these circumstances, many businesses may not be able to continue operations." This level of restriction is likely to be imposed once every 6-10 years in Mapua. For more details see page 35 ESC_21062018_ATT.PDF Engineering Services Committee Agenda June 21 2018 or email Bruno.Lemke@xtra.co.nz

Other comments in the monthly report related to water infrastructure were:

Planning is underway to collect and pipe storm water from Stafford drive properties to the back of the properties near 72 Stafford Drive and discharge them into an open drain on private property, to be maintained by council.

Construction nearing completion of Mapua Coastal Village Stage 2 installation of private wastewater pumping stations.

Council staff are in the process of preparing a resource consent application for Mapua Stafford Drive/Aranui Road fresh water and wastewater upgrade. This does not include storm water.

Mapua Warf seawall renewal to replace existing Mapua deteriorating concrete seawall is at the design stage.

Temperature sensors have been installed in the wastewater from Mapua Rise to identify properties with stormwater/groundwater entering the wastewater.

The seawall that is maintained by council from Tait street through to the Talleys wall ... has been repaired to a similar standard to that of pre-cyclone events.

In relation to the last point I made a 5 minute presentation in the public forum:

I expressed our disappointment that no extra funds were allocated to any of the stormwater submissions for the long term plan. It is our opinion that proper funding has been lacking for stormwater in Mapua/Ruby Bay and it is unrealistic that the current budgets will cover extra issues revealed by Cyclone Fehi. Further I outlined the inadequacy of the current seawall in relation to the 2011 approved consent. Including the standard to the Tait street access to the beach. I presented the diagrams on the next page and talked in particular about the clay bund in the existing seawall preventing overtopping wave water from returning to the sea. I also talked about the consent requiring access over the seawall to the beach and complained about the dangerous state of repair of the current access steps at the end of Tait Street.

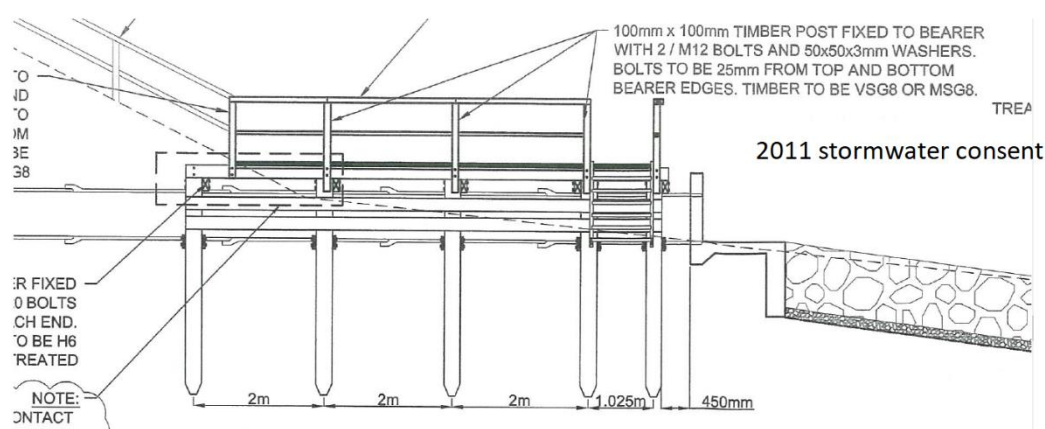
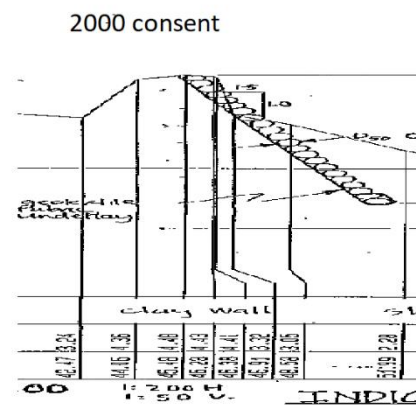
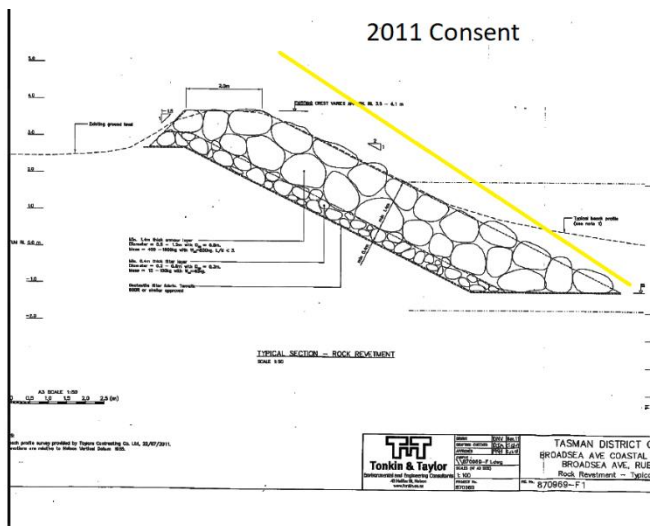

I will be putting the following motions at the next MDCA monthly meeting:

- 1) Recommend we write to council thanking them for the proposed stormwater improvement to houses near 72 Stafford Drive and ask that it includes discharging this water via a new outlet to the sea so the Broadsea avenue outlet in Chaytor reserve is not further overwhelmed.
- 2) Recommend that the seawall from Chaytor reserve to just north of Tait street be repaired to that specified in the 2011 Consent that does not include the clay bund (which prevented wave overtopping water from draining back out to the sea).
- 3) Recommend that the board walk at the end of Tait street which allows access to the beach, is reinstated to a safe and working condition.